

Inovação e Tecnologia para o Turismo

Miguel Mira da Silva

Miguel Mira da Silva

- Professor
- Investigador
- Inovador
- Consultor
- Empreendedor

Desemprego

- Maior problema do mundo
 - Nunca foi tão difícil criar (novos) empregos
 - Nunca houve tanta inovação tecnológica!
- Livros recentes sobre o assunto
 - “Race against the machine”
 - “The coming jobs war”

Inovação

- Inovação significa aumento de produtividade
- Acredito que estamos no início de uma NOVA REVOLUÇÃO tecnológica – dos serviços para os **serviços digitais** – que já começou a destruir os empregos (manuais) existentes
 - Temos de começar a criar novos tipos de emprego em grande escala e urgentemente

Technological Revolutions

- It is not the first time!
 - For thousands of years, most people worked on **agriculture using horses...** not any more
 - For 200 years, most people worked on **industries using machines...** not any more
 - For 50 years, most people work on **services using computers...** but for how long?

Inovação no Turismo

- Aplicações práticas da nossa investigação
 - Identificação de serviços
 - Qualidade dos serviços
 - Automatização de actividades
 - Análise de custos com ABC
 - Níveis de maturidade
 - Oops Booking

Identificação de Serviços

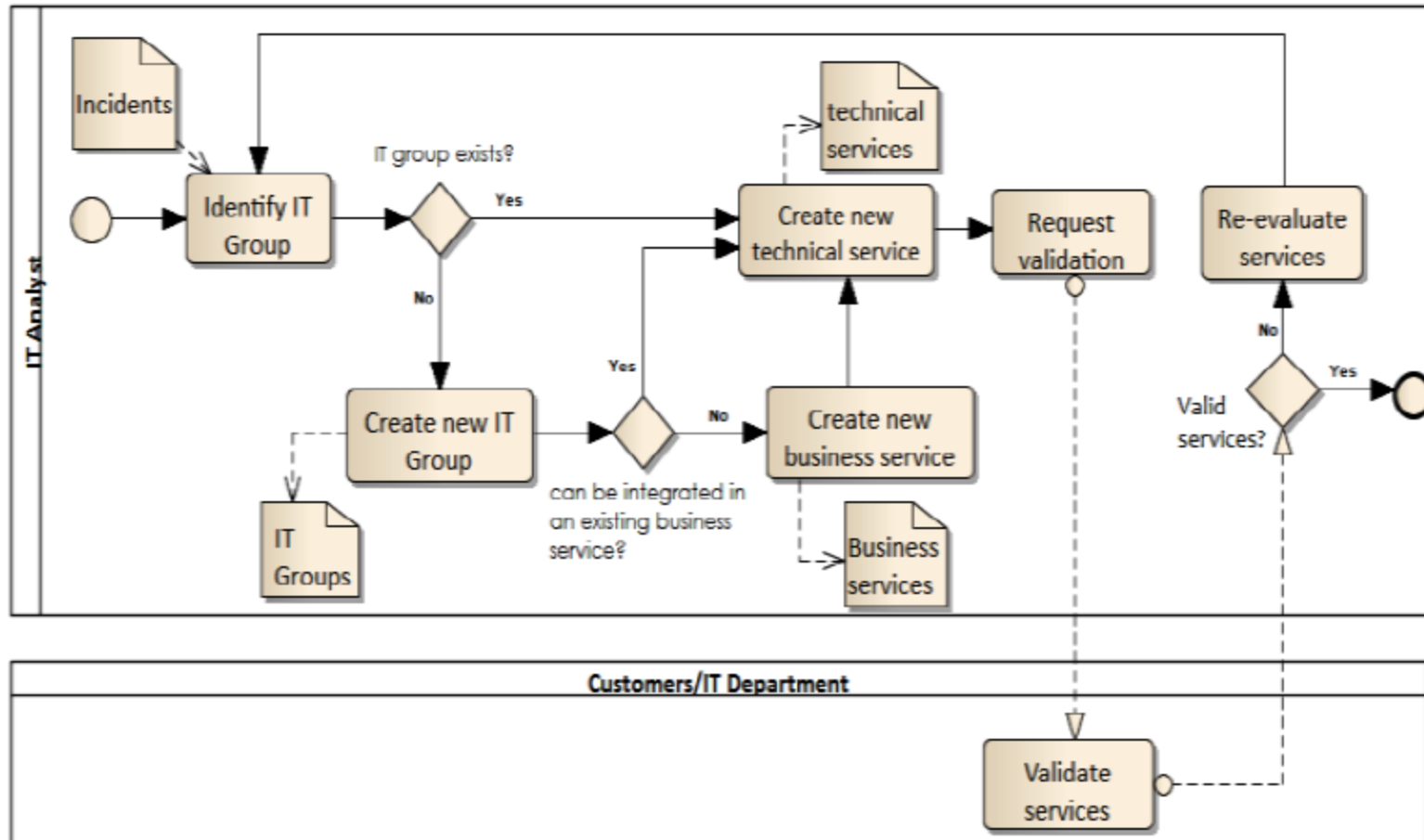

Catálogo de Referência

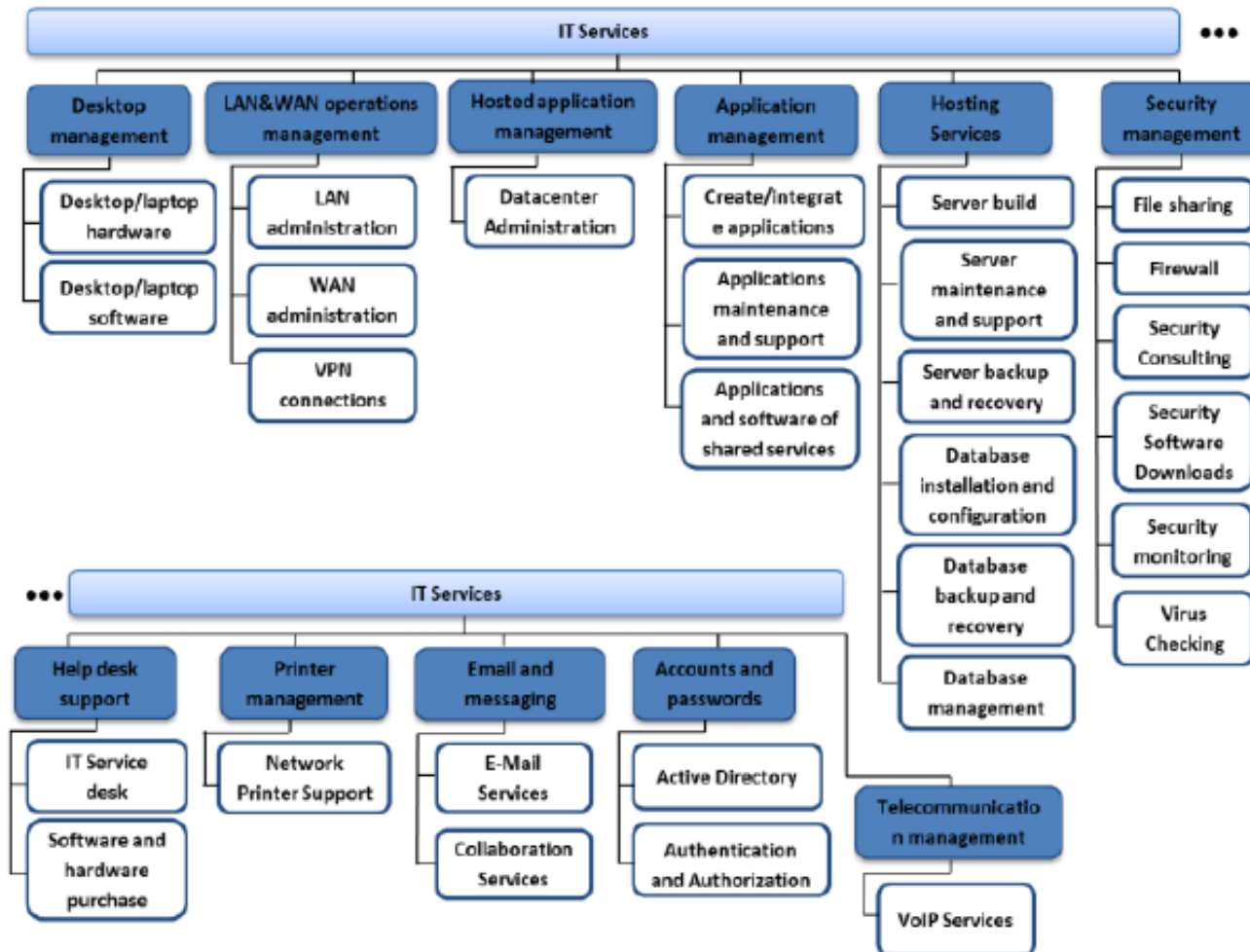

Qualidade dos Serviços

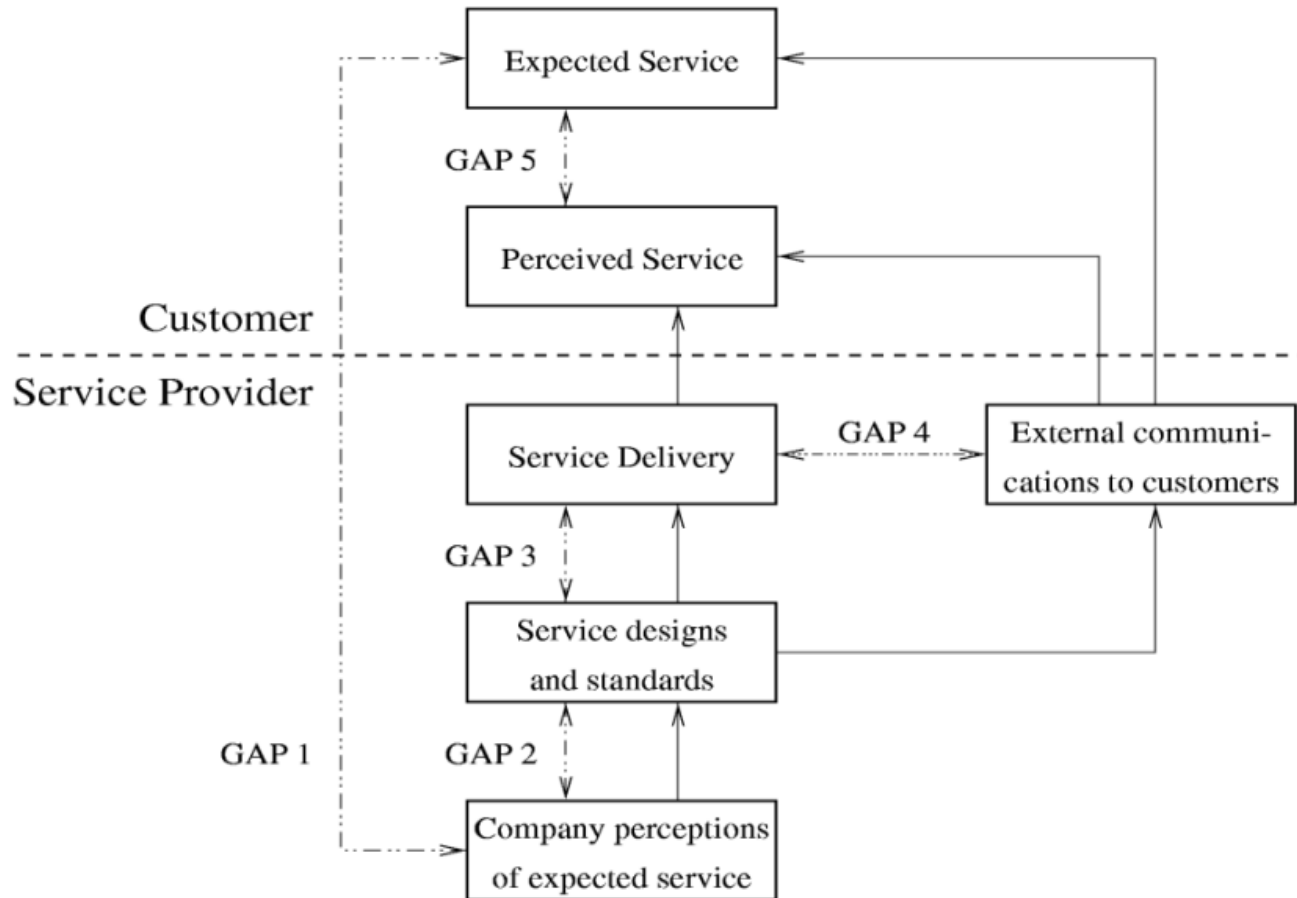

Solução com DEMO

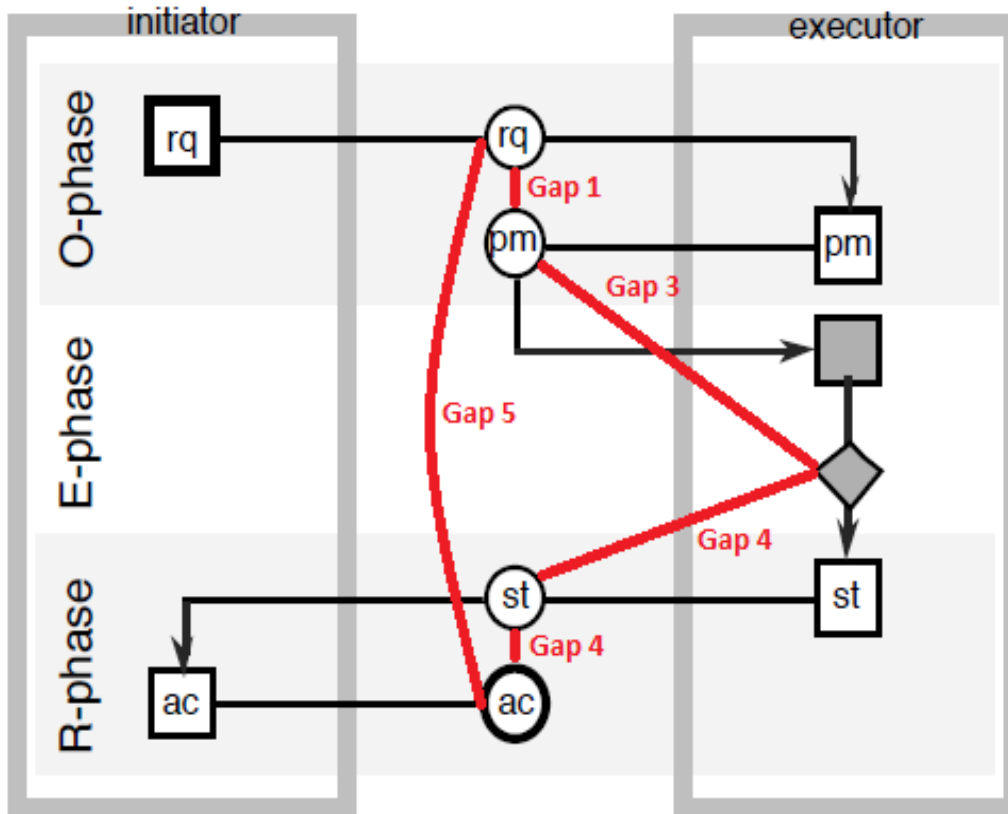

rq: request
pm: promise
st: state
ac: accept

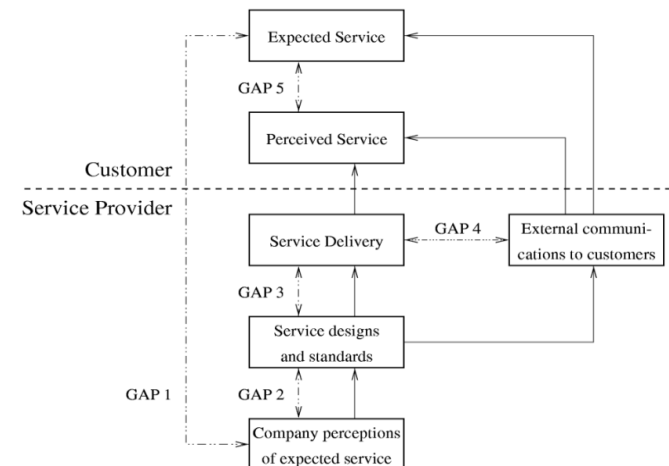

Urgências em DEMO

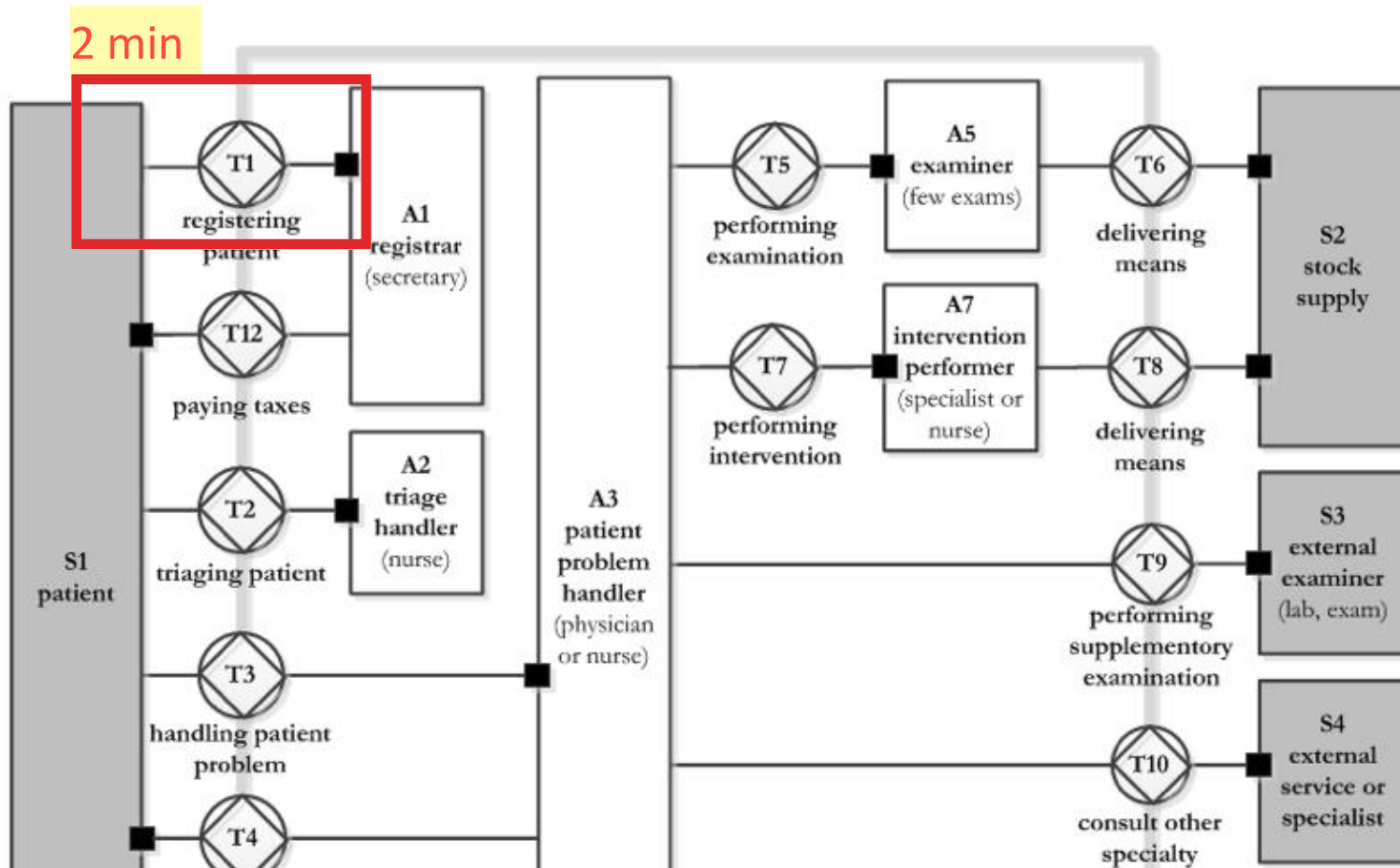

For 100,000 admissions, the cost is 300,000 euros

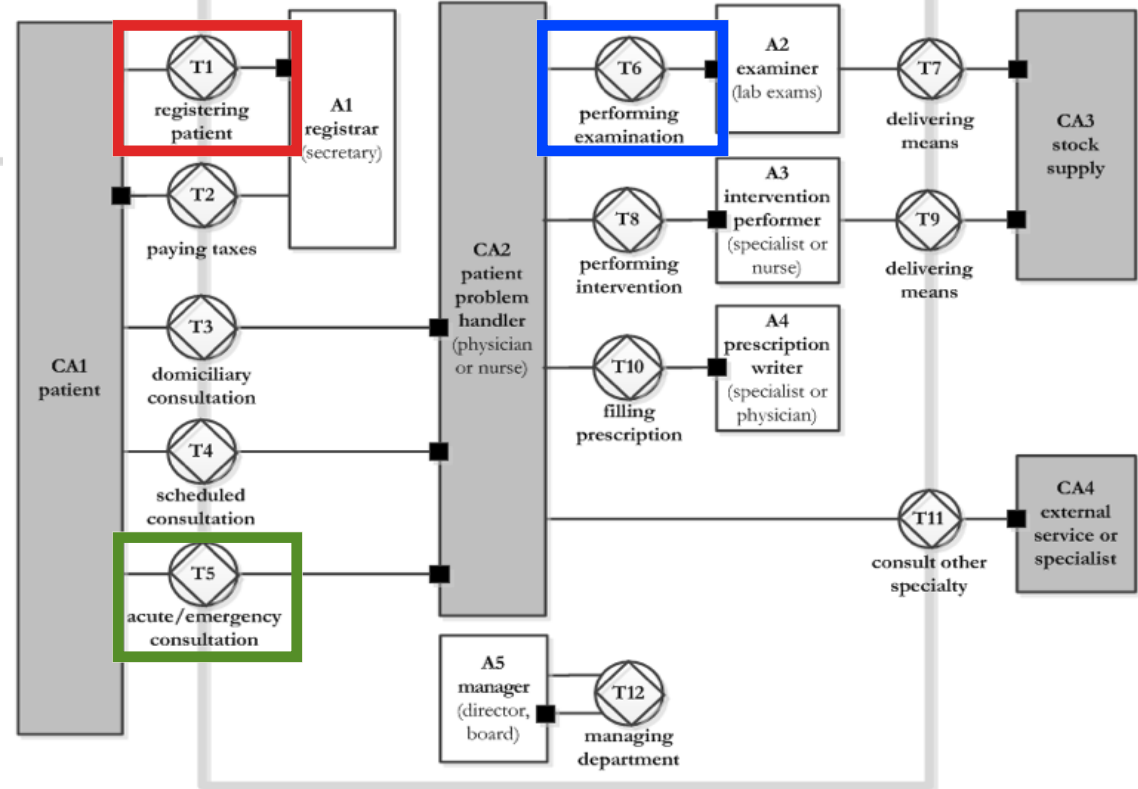
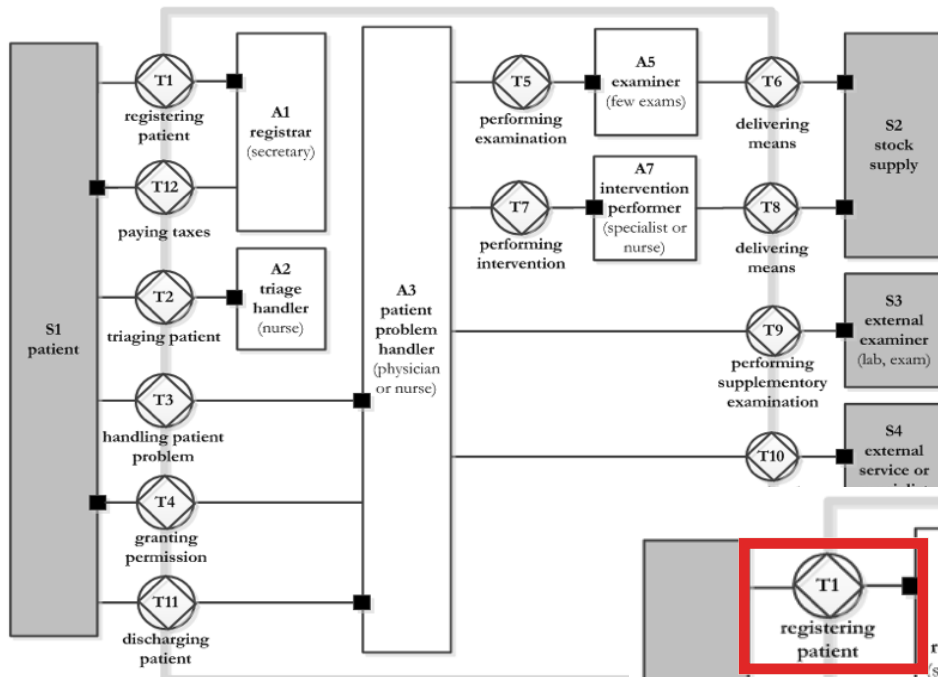

Análise de Custos



Gráfico da Baleia

Whale curve of cumulative profits

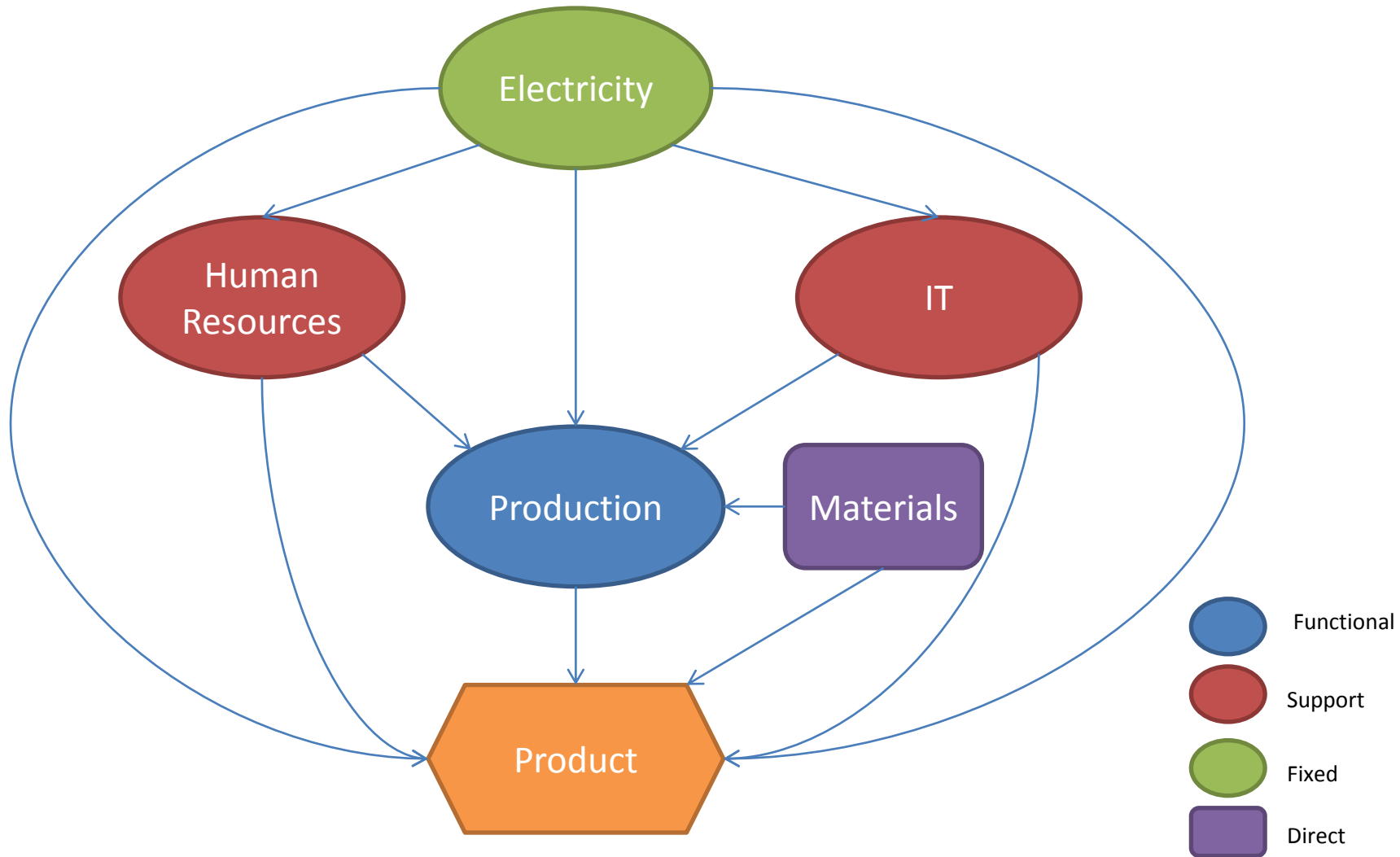

Exemplo: Farmácia

- Só atender um cliente custa 1,36 euros
 - Portanto a farmácia perde dinheiro na grande maioria dos atendimentos

PVA	Margin
<5€	27,9%
>5€ < 7€	25,7%
>7€ < 10€	24,4%
>10€ < 20€	21,9%
>20€ < 50€	18,4%
>50€	<18,4%

1,35€

10€

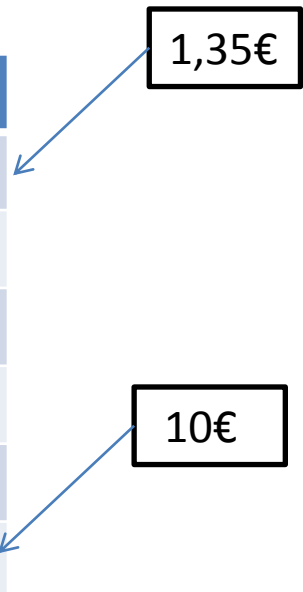

IT Capability Maturity Framework™

A CIO Compass to Meet New Challenges

Based on a framework originally developed by Intel IT
Refined and extended by the Innovation Value Institute (www.ivi.ie)
Reviewed and tested with 300+ CIOs

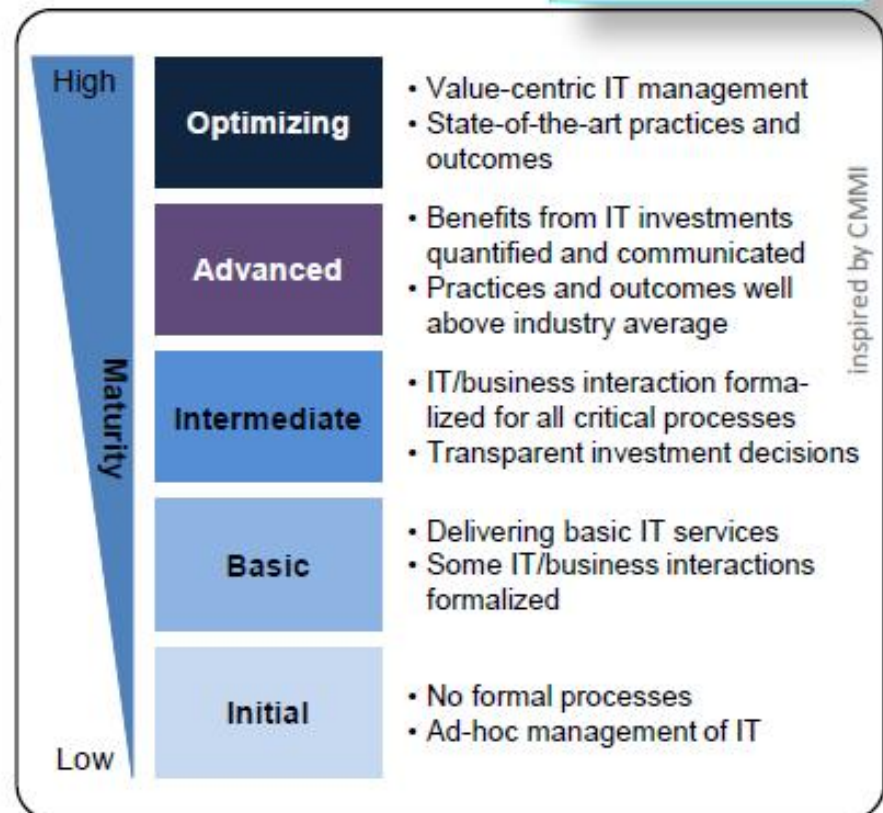
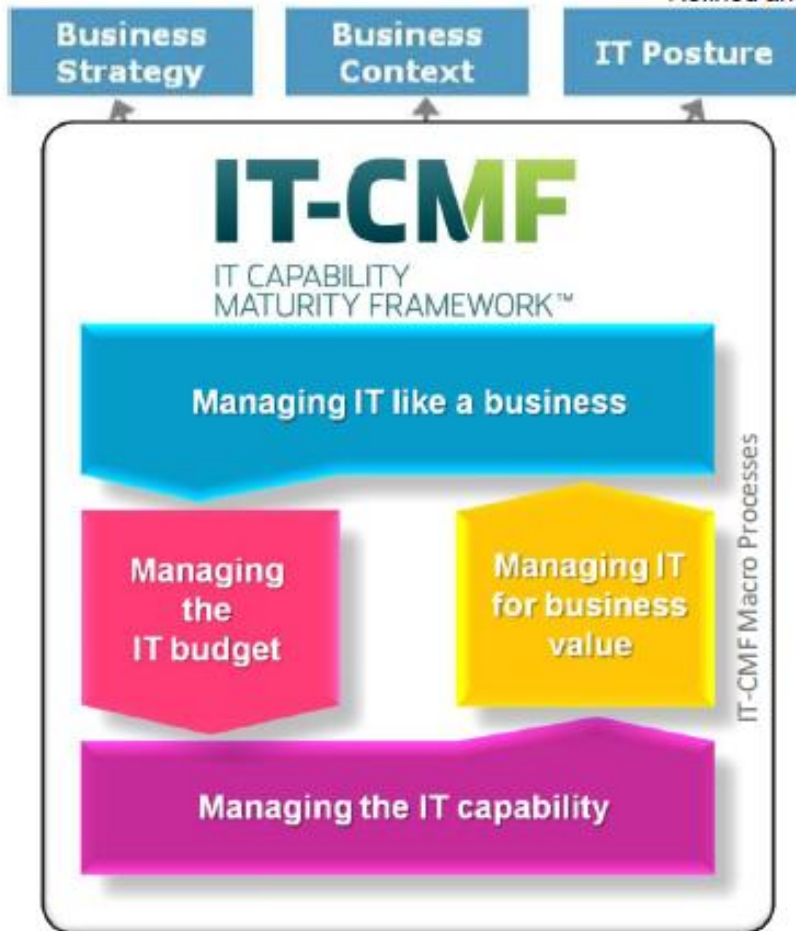

Maturity Framework

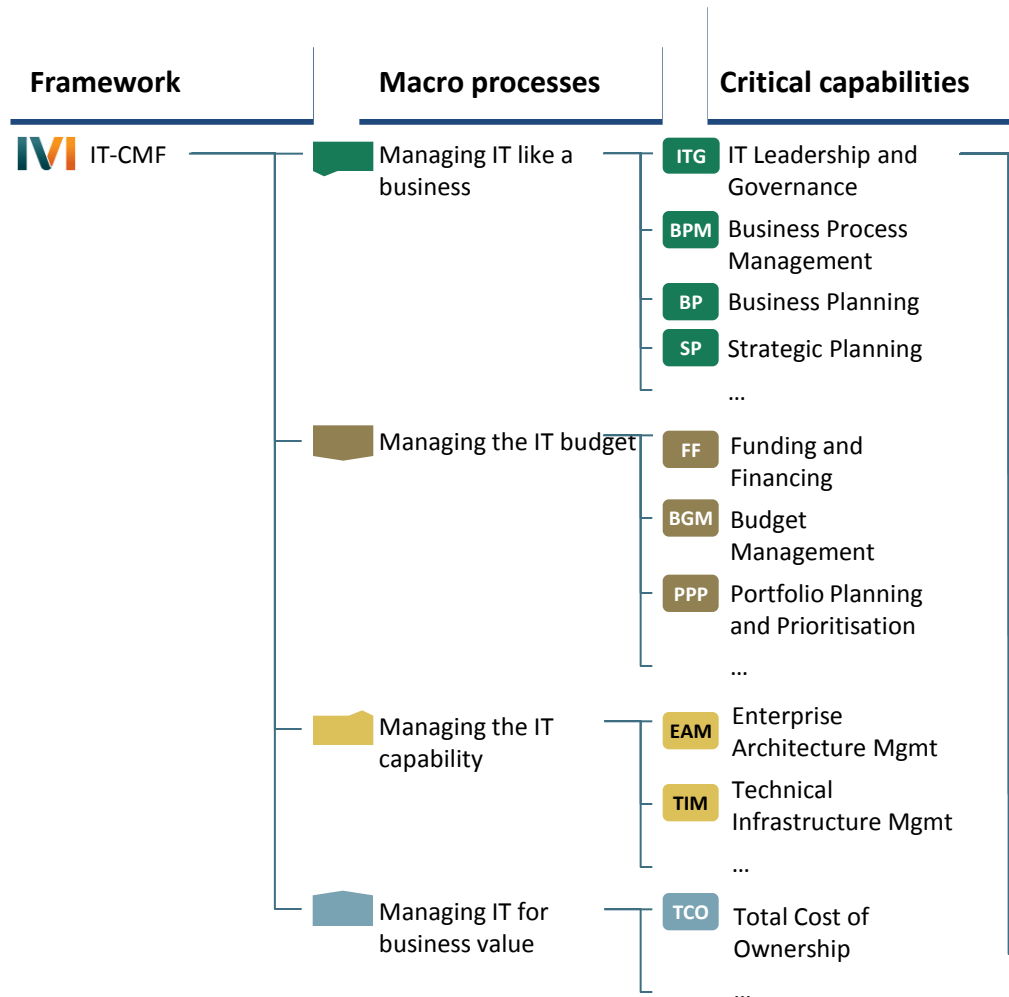

Oops Booking

ANZ Aeroportos
de Portugal

Oops!
booking

inov
inesc • inovação

TURISMO DE
PORTUGAL



mytable[®]
Já reservou mesa para hoje?

yellow
HOTELS

**inside
lisbon**

Pestana
HOTELS & RESORTS

LX[®]
boutique
hotel

Oops Booking



Oops Booking



Contactos

Miguel Mira da Silva

Tel. 919.671.425

mms@ist.utl.pt